

Nº5105

Nº5105 MC

TURNTABLE OWNER'S MANUAL

mark
LeVINSON®

**IMPORTANT:
READ BEFORE PROCEEDING!**

- Read and follow the instructions
- Keep all instructions for your reference.
- Save all packing materials. The N^o5105 should only be moved or shipped in its original packaging to reduce the risk of damage in transit.

**IMPORTANT SAFETY
INSTRUCTIONS**

**PLEASE SEE ADDITIONAL
SAFETY INSTRUCTIONS
INCLUDED IN THE PACKAGE**



**FOLLOW THE INSTRUCTIONS
BELOW TO REDUCE RISK OF
ELECTRICAL HAZARD OR INJURY.**

1. To avoid electrical shock, do not open the motor housing.
2. To avoid electrical shock, always plug the N^o5105 into a grounded outlet.
3. If the power cord provided with the N^o5105 does not reach an outlet, use a heavy-duty, grounded extension cord.
4. Use the N^o5105 in a controlled temperature environment.
5. Install in accordance with the manufacturer's instructions.
6. Refer to the operating instructions for power requirements. Be advised that different operating voltages may require the use of different line cord and/or attachment plug.
7. Never attach audio power amplifier outputs directly to any of the unit's connectors.

In case of any damage or question please contact your authorized Mark Levinson dealer.

Thank you for your investment in a N^o5105 turntable. For nearly 50 years, discerning individuals have chosen Mark Levinson products for their luxurious quality and revealing sound. Robust materials, lavish finishes, bold geometry, and outstanding performance are celebrated attributes of the Mark Levinson brand. The N^o5105 Turntable is made with the finest materials, technology, and craftsmanship in the world and will deliver outstanding performance for many years to come.

For optimum performance, please read this guide and follow the unpacking and set up instructions carefully.

PACKING

PARTS

- 1 – Chassis with mounted tonearm
- 2 – Record weight
- 3 – Platter
- 4 – Alignment template

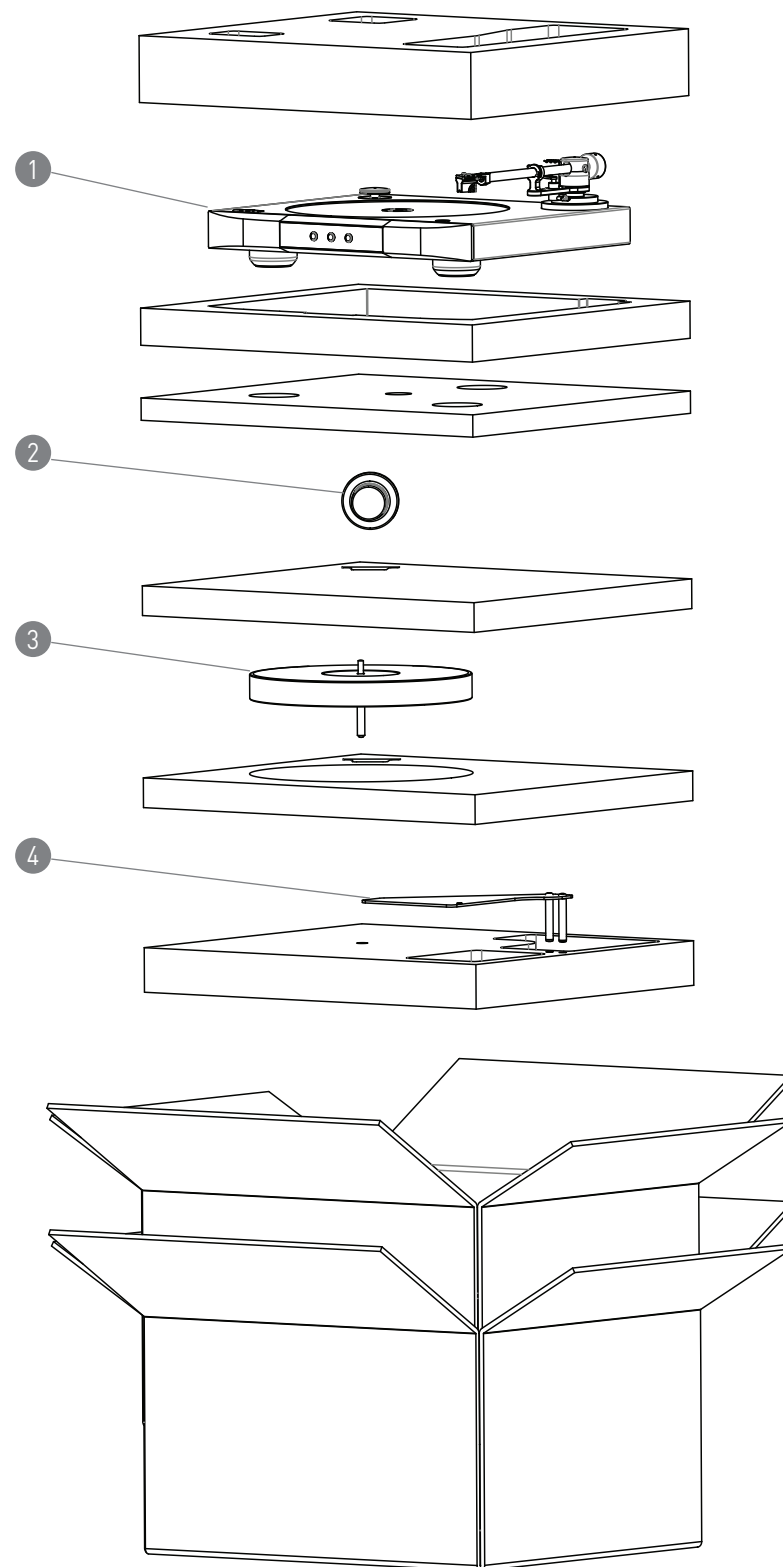

SETUP

PREPARATION

To avoid transport damage your N°5105 comes in carefully designed packaging and is partially preassembled. Make sure you have plenty of clear flat space to unpack and set up the N°5105. We recommend at least 2ft x 2ft flat surface to set up.

UNPACKING THE BOX

It is important that you save the packing materials and box to use for shipping or moving the N°5105. Remove the chassis and place it on the designated surface. The N°5105 must be placed on a flat, level surface capable of supporting its considerable weight (75 lbs). This will make setup easy and put less strain on the main bearing. The stronger and better isolated the shelf or stand is, the better the N°5105 will sound.

- Remove and set aside these items:
 - Alignment template
 - Record weight
 - Power cords
 - Anti-skating weight
 - Bearing oil
 - Belt
 - 12" LP jacket containing the manual and platter mat

LEVELLING

After placing the chassis, you can now level the turntable by turning the 3 feet in the chassis. Turn the feet right for lowering the chassis and left to lift it. Use the integrated bubble level for adjustment.

MOUNTING THE PLATTER

Take away the cover strip over the bearing hole.

Insert the platter carefully into the bearing. Take care that it slides in slowly and easily. **Do not let the platter drop into the bearing hole, as this may damage the bearing.**

Turn the platter by hand to make sure it spins easily. Let the platter settle for about 15 minutes before turning on the motor.

Note: The bearing is factory lubricated, and is generally maintenance free. The bearing oil is included as a courtesy in case service is needed in the future.

MOUNTING THE BELT

Place the provided belt around the platter (1) and then around the pulley (2). Turn platter by hand to align belt on tread. **Do not use sharp tools or pointed tweezers. This may damage belt, platter and pulley.**

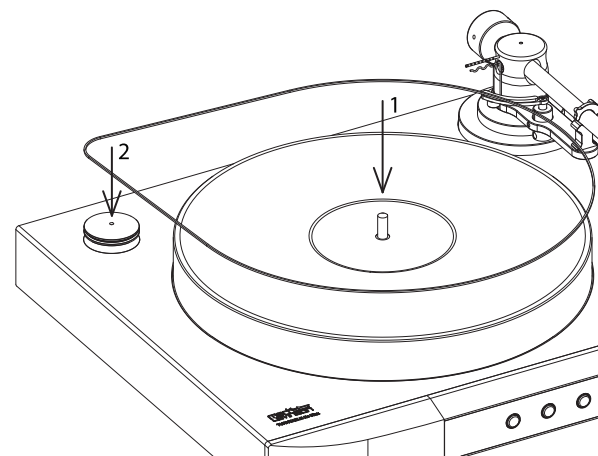

TO NEARM

Set up with standard cartridge

If you purchased a N°5105 MC, it will have the cartridge mounted and its tonearm adjusted. The only thing you must do is to set the anti-skating (as detailed on the next page).

INSTALLING AND ALIGNING A CARTRIDGE

(If you purchased the N^o5105 MC, a pre-mounted and calibrated cartridge is included; skip this section.)

If you chose to mount an alternative cartridge, please use the included alignment template to adjust it to your turntable. Use the inner grid of the template to adjust your cartridge.

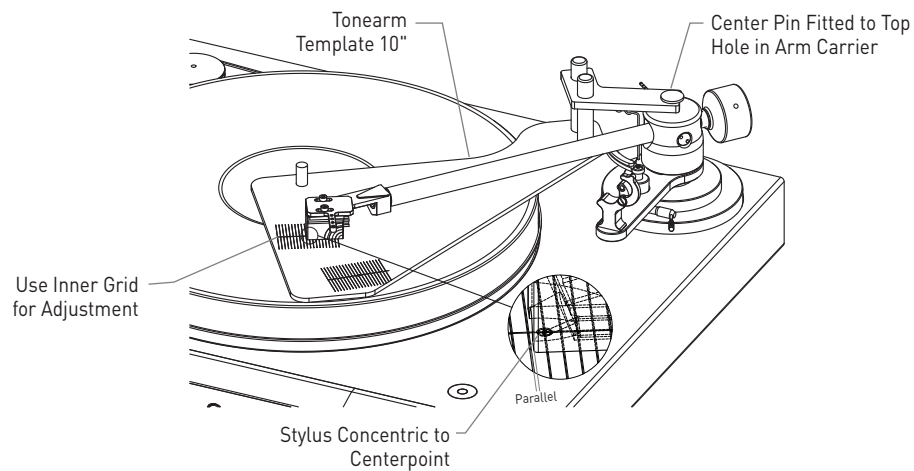

To alter the height of the tonearm (VTA adjustment), loosen the VTA locking screw (M4 set screw) on the rear side of the armboard, using a 2 mm hex key. **Please be very careful when moving the tonearm and do not try to pull it out.** The tonearm is internally attached to a PCB for the output signal.

Azimuth can be adjusted by loosening the azimuth locking screw (M3 set screw) in the headshell, using a 1.5 mm hex key.

- For cartridges with threaded mounting holes, use the screws supplied by the cartridge manufacturer. Other screws may not fit properly and may cause damage to the threads and cartridge.
- For cartridges with pass-through mounting holes, use the hardware supplied with the tonearm. Be sure to use washers under the screw heads.
- The tonearm wires are color-coded as follows:
 - Red – right hot
 - Green – right ground
 - White – left hot
 - Blue – left ground.

Note that if your phono preamp inverts polarity, you should swap the hot and ground wires to the cartridge, e.g., red wire to green terminal and green wire to red terminal. Do not swap the channels.

- Using tweezers or fine-tipped pliers, grip the center of the red wire's connector – not the wire itself – and push it onto the cartridge's right hot terminal pin. Connect the remaining connectors in the same way. To avoid damage to the cartridge, do not push the connectors all the way on.
- Place the alignment template on the spindle with back against the tonearm assembly base and place the record spindle through the hole.

Note that the following steps to align the cartridge must be performed without any stylus guard or protection device in place. Be careful not to bump or damage the stylus or cantilever.

- Swing the tonearm over the alignment template so the stylus is as close as possible to the center of the grid. Set the counterweight for just enough downward force to keep the stylus from moving when resting on the template. Be sure to lift the stylus off the template whenever adjusting the counterweight so as not to damage it or the cantilever.
- With the diamond stylus resting in the center of the alignment template, use a flashlight and look from the front of the cartridge to align the cantilever with the grid lines on the template. The alignment of the cartridge body is unimportant compared to that of the cantilever. Adjust the cartridge mounting screws and counterweight as needed during this process.

SETTING THE ANTI-SKATING

With modern tonearms and cartridges, not all users prefer to enable anti-skating devices. The N^o5105 anti-skating device is mounted on the tone arm pivot.

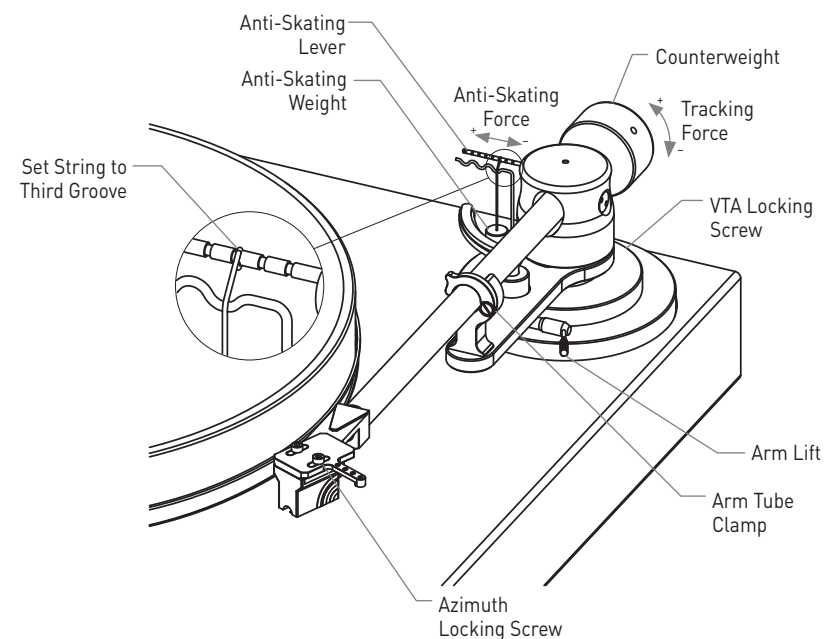

If your turntable has a factory installed cartridge, set the anti-skating weight to the third groove of the anti-skating lever and lead it into the innermost wave of the string support (reference image above). If you are installing your own cartridge, anti-skating force can be adjusted by moving the weight line into different groves.

- Put a record on the platter, turn the motor on, and put the stylus down on the record. Looking from the front, observe whether the cantilever is deflected while the record is playing, or if the tonearm shifts when lifting the stylus out of the groove. If the cantilever is deflected toward the center of the record (i.e. the tonearm is being forced away from the center of the record) then the anti-skating force is too high. The force can be reduced by moving the weight line toward the central pivot.
- Check the anti-skating force at several points between the outer and inner grooves of the record, and adjust the weight as needed. Moving the line loop to a groove farther from the pivot increases anti-skate, and moving it closer reduces anti-skate.
- Additionally, anti-skating can be adjusted by listening to a record. Excessive distortion in the left channel indicates too much anti-skating force, whereas distortion in the right indicates not enough force.

CONNECTING THE N°5105

Connect the N°5105 in 3 steps:

1. Connect the left and right RCA terminals to the phono inputs of a preamplifier using a high quality interconnect cable.
2. Connect the ground terminal to the ground terminal on the phono input of the preamplifier.
3. Select the appropriate included power cord for your region, and connect it to the wall outlet.

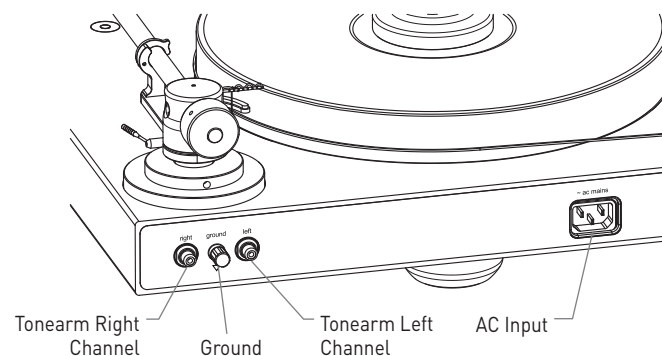

OPERATION

OPERATING THE TURNTABLE

When connected to the AC mains, the N°5105 immediately enters *Standby* mode, which is indicated by a slowly blinking light ring around the Standby/Stop button.

- To start the platter, press the button labeled with the desired speed. The light ring around the speed button will illuminate, and the platter will slowly come up to the chosen speed. The speed increases slowly to minimize wear on the belt.
- To stop the platter, press the Standby/Stop button once to stop. The light ring around the Standby/Stop button will illuminate, and the platter will slowly come to a stop (because of its high mass).
- To put the N°5105 back into *Standby* mode, press and hold the Standby/Stop button for three seconds. The light ring around the Standby/Stop button will start to blink slowly, indicating that the unit is in *Standby*.

OPERATING THE TONEARM

- Open the arm tube clamp.
- Raise the tonearm by turning the lever on the tonearm lifter clockwise.
- Position the cartridge over the inlet groove of vinyl record.
- Lower the stylus onto the record by turning the lever on the tonearm lifter counterclockwise.
- When the record has finished playing, lift the tonearm again and return it manually to the park position.

GENERAL USE

- For best performance allow at least 20 hours of break-in time.
- You can experiment with different platter mats, but be sure to recheck and adjust the VTA setting as needed.

DIMENSIONS

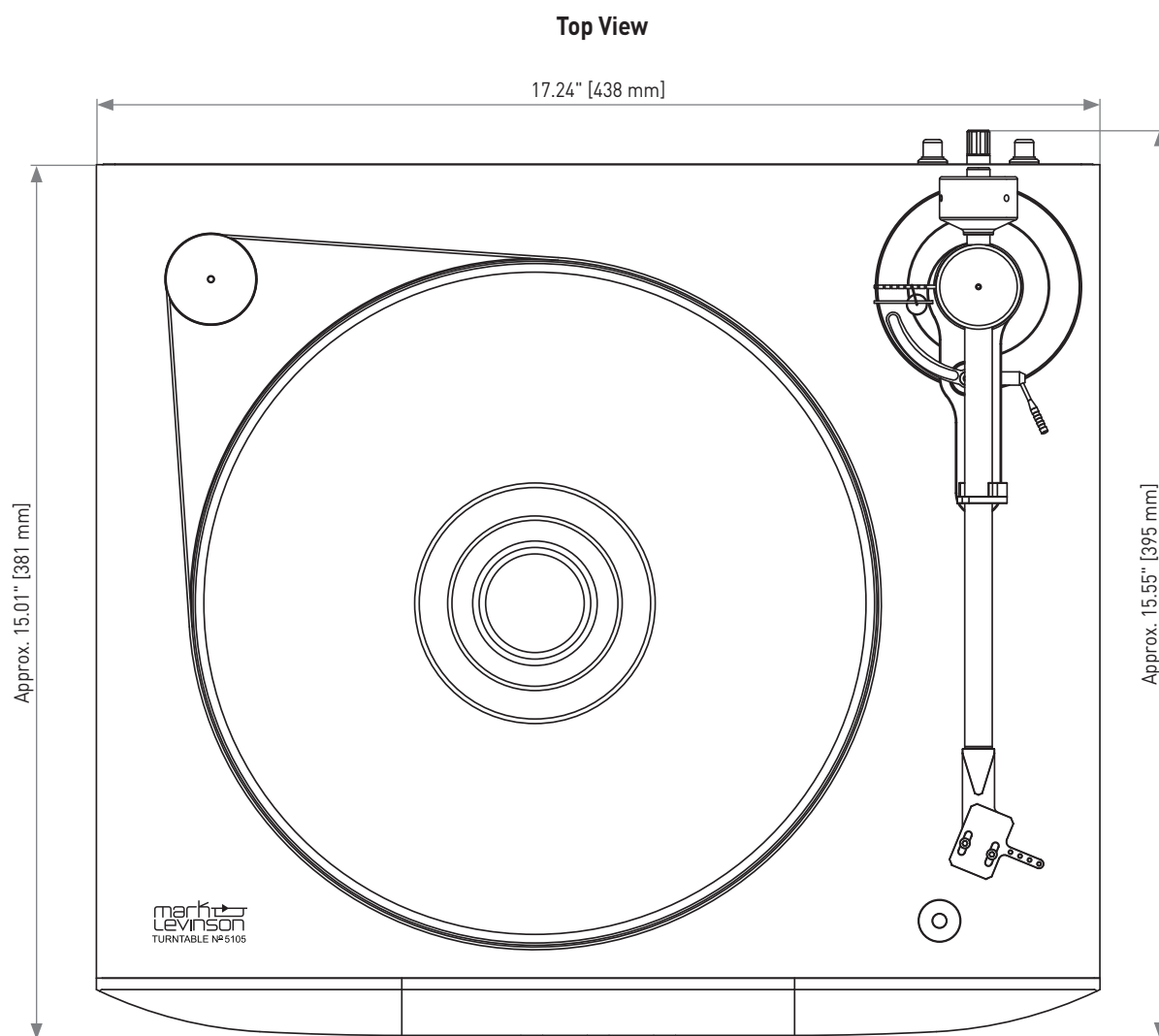

SPECIFICATIONS

TURNTABLE N°5105 / TECHNICAL DATA

Dimensions: 17.2" x 15.6" x 6.1" / 438 mm x 395 mm x 154 mm

Weight: 75 lbs / 34 kg

Drive system: Integrated DC-motor

Speed range: 33 1/3 RPM and 45 RPM

Power supply: Internal AC to DC power adaptor; input 100V to 260V AC 50-60Hz

Bearing: High precision bearing

Chassis: 17.2" x 15" x 2" / 438 mm x 380 mm x 50 mm; aluminum; 3 height adjustable feet

Platter: 11.75" diameter x 1.33" / 299 mm diameter x 34 mm; aluminum; weight: 13 lbs / 6 kg

Tonearm: Effective length 10"; mounting distance 9.36" / 237.8 mm; overhang 0.64" / 16.2 mm, height adjustable

Front View

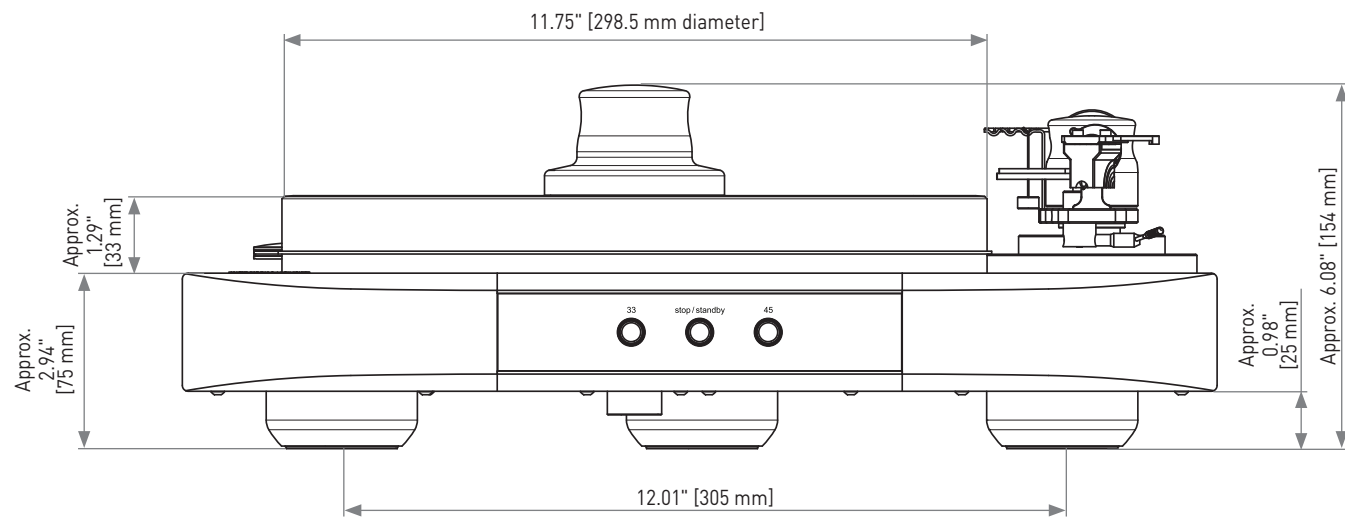

Right View

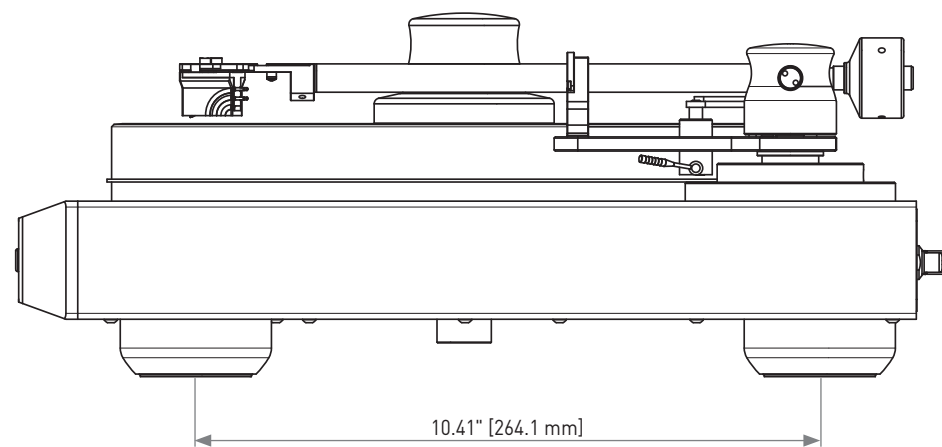

Rear View

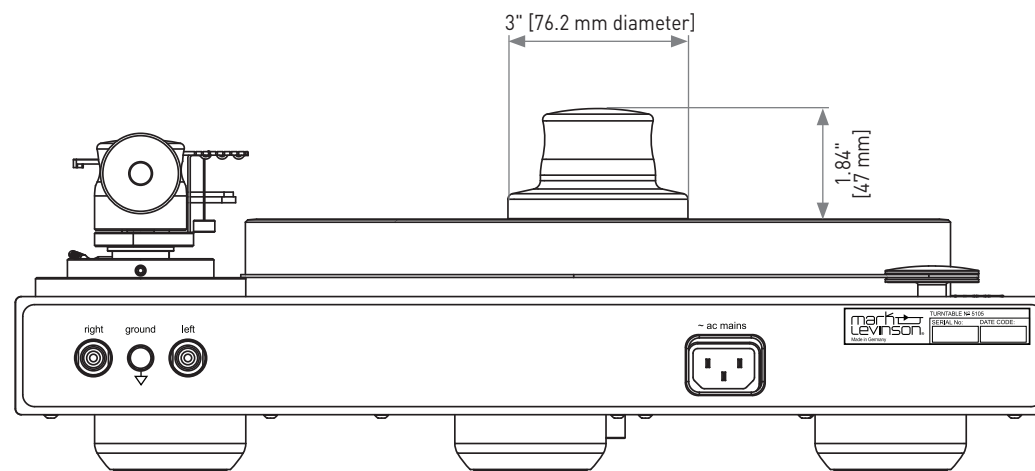

For more information please visit www.MarkLevinson.com



HARMAN International Industries, Incorporated
8500 Balboa Boulevard
Northridge, CA 91329 USA

(818) 893-8411 (USA only)

© 2020 HARMAN International Industries, Incorporated. All rights reserved.

Mark Levinson is a trademark of HARMAN International Industries, Incorporated,
registered in the United States and/or other countries.

Part No. 070-00006 (rev. B.0)

www.MarkLevinson.com